

◇ MAKOBA
MULTICRACKER®

MC370

The bestseller

- ◇ Up to 80 % energy saving
- ◇ Up to 30 mt/h throughput
- ◇ low Powder Fraktion

Advantages:

- ◇ gentle, efficient processing of valuable raw material
- ◇ homogenous ground product
- ◇ no material heating
- ◇ compact design
- ◇ PLC-capable integration



STANDARD-CONFIGURATION

Electrical stepless adjustment of the grinding gap
Controls/switch cabinet not included

Quick-action exchange of the crackerunit

Enclosed crackerunit

Foreign object protection by spring technique

Incl. one crackerunit/grinding unit

Disk profile of your choice

Vibration damping mounting feed,
bearing temp. sensors

EC-conform, ATEX certified (zone 22)

IDEAL AREAS OF APPLICATION

Grains

Legumes/nuts

Seeds

Oil-extraction meal/cake

Herbs/Teas

Pharmaceuticals

Chemicals

...and much more

TECHNICAL DATA/SPECIFICATIONS

Input chute: 462 x 242 mm

Output chute: 462 x 150 mm

Outer dimensions: (see drawing)

Driving power: 2x 18,5 kW

Weight: 1300 kg

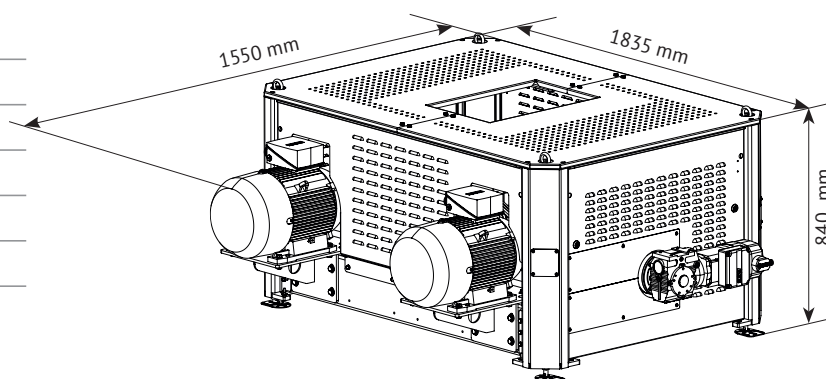

MAKOBA GmbH & Co.KG
Lochfeldstr. 28
D-76437 Rastatt

Tel +49 7841 67197-0
vertrieb@makoba.de

