

◇ MAKOBA  
**MULTICRACKER®**

## MC300

### The all-rounder

- ◇ Energy consumption approx. 1 kWh/mt
- ◇ Up to 80% energy saving
- ◇ low Powder Fraktion

#### Advantages:

- ◇ gentle, efficient processing of valuable raw material
- ◇ homogenous ground product
- ◇ no material heating
- ◇ compact design, little floor space
- ◇ PLC-capable integration

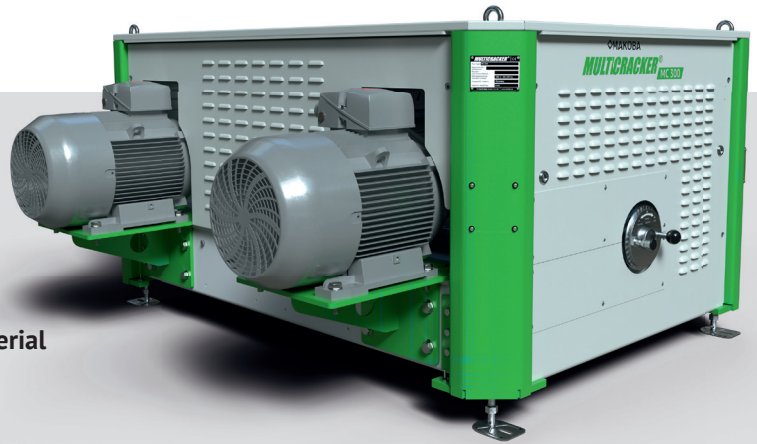

#### STANDARD-CONFIGURATION

---

Manual, stepless adjustment of the grinding gap

---

Quick-action exchange of the crackerunit

---

Enclosed crackerunit

---

Foreign object protection by spring technique

---

Incl. one crackerunit/grinding unit

---

Disk profile of your choice

---

EC-conform, ATEX certified (zone 22)

---

#### IDEAL AREAS OF APPLICATION

---

Grains

---

Legumes/nuts

---

Seeds

---

Oil-extraction meal/cake

---

Herbs/Teas

---

Pharmaceuticals

---

Chemicals

---

...and much more

#### TECHNICAL DATA / SPECIFICATIONS

---

Input chute: 462 x 242 mm

---

Output chute: 462 x 150 mm

---

Outer dimensions: (see drawing)

---

Driving power: 2x 15 kW

---

Weight: 1300 kg

---

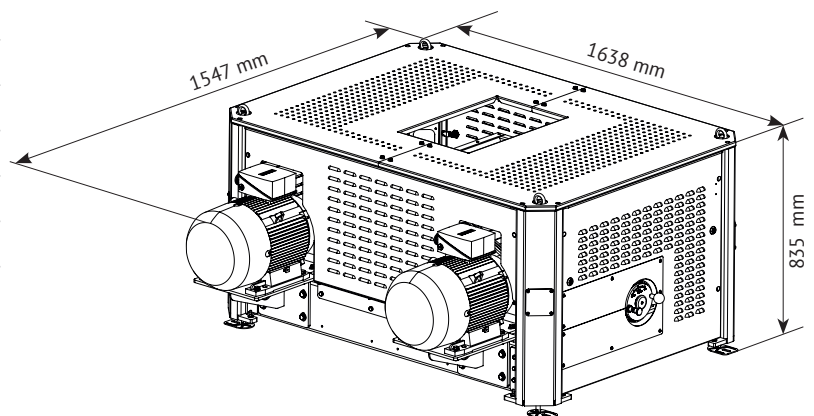

MAKOBA GmbH & Co.KG  
Lochfeldstr. 28  
D-76437 Rastatt

Tel +49 7841 67197-0  
vertrieb@makoba.de

