

◇ MAKOBA **MULTICRACKER®**

MC15

The perfect entry
into modern grinding technology

- ◇ Up to 11 mt/h throughput
- ◇ Up to 80 % energy saving
- ◇ low Powder Fraktion

Advantages:

- ◇ gentle, efficient processing of valuable raw material
- ◇ homogenous ground product
- ◇ no material heating
- ◇ dustproof grinding unit
- ◇ compact design, little floor space
- ◇ PLC-capable integration



STAINLESS
STEEL
VERSION
AVAILABLE

STANDARD-CONFIGURATION

Manual, stepless adjustment of the grinding gap
Incl. one crackerunit/grinding unit
Dustproof grinding unit
Foreign object protection by spring technique
Quick change crackerunit
Disk profile of your choice
EC-conform, ATEX certified crackerunit

IDEAL AREAS OF APPLICATION

Grains
Legumes
Seeds
Extraction meal/cake
Herbs/tea
Pharmaceuticals
Chemicals

...and much more

TECHNICAL DATA/SPECIFICATIONS

Input chute: DN 250 (others available)
Output chute: DN 250 (others available)
Outer dimensions: (see drawing)
Drive power: 2x 7,5 kW
Weight: 580 kg

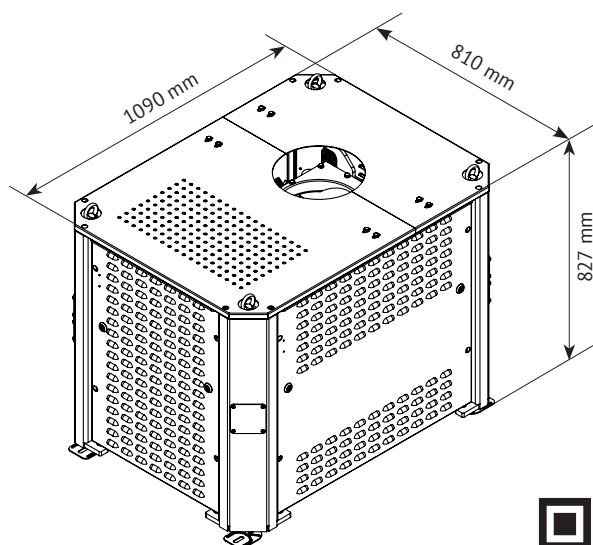

MAKOBA GmbH & Co.KG
Lochfeldstr. 28
D-76437 Rastatt

Tel +49 7841 67197-0
vertrieb@makoba.de

